



DISPOFLEX

# **Dispositivos Flexibles S.A. de C.V.**

## **Textile Expansion Joints**





DISPOFLEX

**Dispositivos Flexibles S.A. de C.V.**

**Product Catalog**

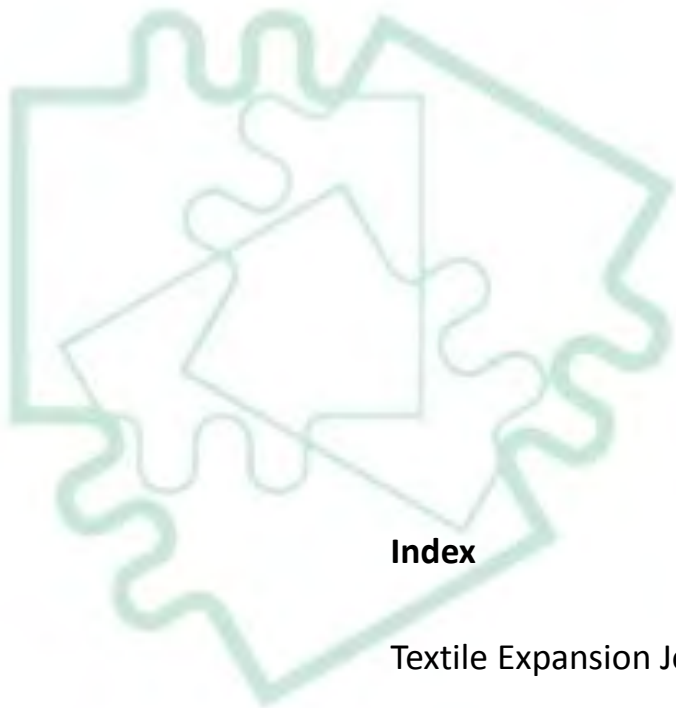

## **Index**

Textile Expansion Joints.

Manufacturing.

Textile Expansion Joint are composed by:

Types of Textile Expansion Joints.

Types of Manufacturing.

Advantages.

## Textile Expansion Joints

Non metallic or textile expansion joints are specially designed to conduct gases, chemical vapor or abrasive gases. For this reason the fabrics used are resistant to high temperatures, abrasion and corrosion, as well as wearing weather conditions.

Its design allows it to compensate axial, angular, lateral movement or torsions on their own or simultaneously, present in the pipe system.

Principally used in pipe systems with gases, hot air, dust o vapors, chimneys and energy generating plants. Its materials resist fluids up to 1200°c (2200°f) and usual pressures under 0.35 kg/cm<sup>2</sup> (5 psi).

As well as other expansion joints they are manufactured according to the needs, involved factors and required size.



# Manufacturing

Depending on the use given to the expansion joint, as well as the operation conditions, temperature resistance, pressure and the containing liquid or gas, the material is different. The material used can be of different types.

## Fabric:

- Glass fiber
- Polyester
- Nylon
- Cotton
- Kevlar
- Ceramic

## Elastomer:

- Hypalon
- Nitrile
- Neoprene
- Polyurethane
- Silicone
- Fluorelastomer

## Others:

- Plastic lamina
- Metallic lamina
- Metallic mesh
- Insulating felt
- Special accessories



## Textile Expansion Joint are composed by:

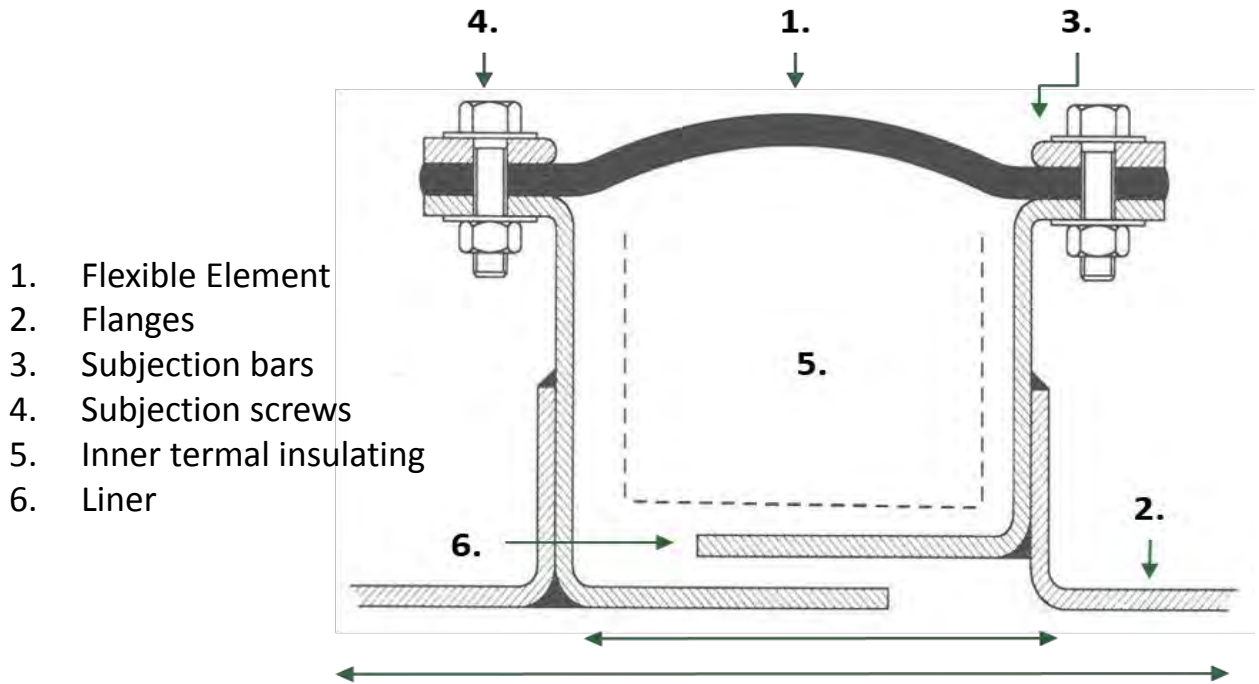

### 1. Flexible Element

Principal element of the expansion joint made of different materials according to the requirements of the installation. Can have one or multiple layers, offering major chemical and high temperature resistance. The outer layer reinforces the mechanical movement of the joint and may be impregnated with elastomer or out of glass fiber covered in silicone to achieve major protection to extreme weather conditions avoiding ageing.

### 2. Flanges

The flanges joint the expansion joint to the duct as well as providing flexibility. They can be circular, rectangular or customized.

## Textile Expansion Joint are composed by:

### 3. Subjection bars

The subjection bars fix the flexible element to the flange. It is important, that the edges of the bars are round, to avoid cutting or tearing of the flexible element.

### 4. Subjection screws

Used to fix under pressure the subjection bars to the flexible element. They are of great duration and resistance and easy to install.

### 5. Inner thermal insulating

Stuffed with ceramic fiber of different thickness and densities, a bag of fabrics or stainless mesh, installed in the space between the flexible element and the liner and used as insulating that allows resistance to high temperatures.

### 6. Liner

Is the installed protection to avoid entry of particles to the inner bag and gases or smokes with dusts and other solid residues won't erode the expansion joint. At the same time it regulates temperature and pressure, avoiding turbulences, loss of charge and sudden changes of temperature in the compensator. The speed of the gases and its particle content determine what type of liner should be used.

# Types of Textile Expansion Joints

**Non-metallic expansion joint with extremes to Weld.**

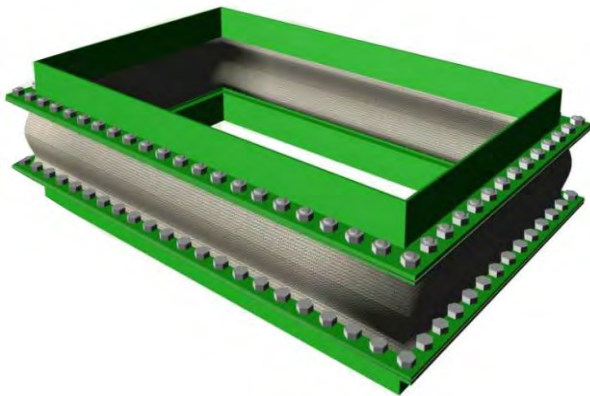

**Non-metallic expansion joint with square flanges**



**Non-metallic expansion joints with flanged extremes and inner sleeve.**

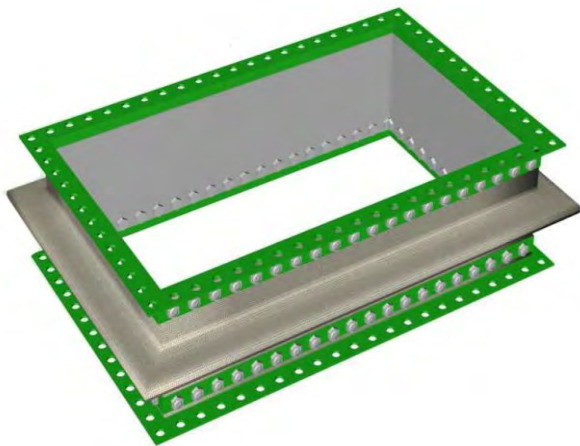

**Non-metallic expansion joint with square flanges and inner sleeve.**

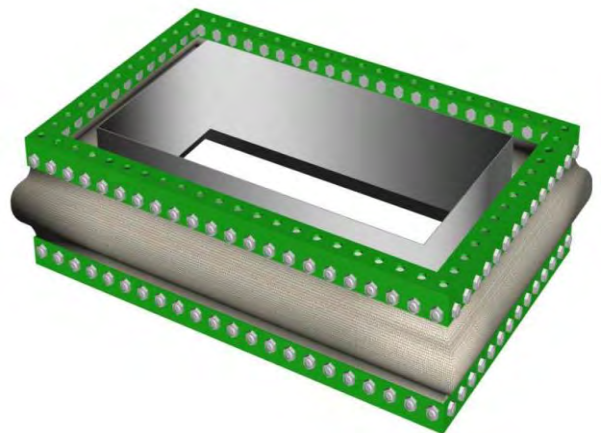



# Types of Manufacturing

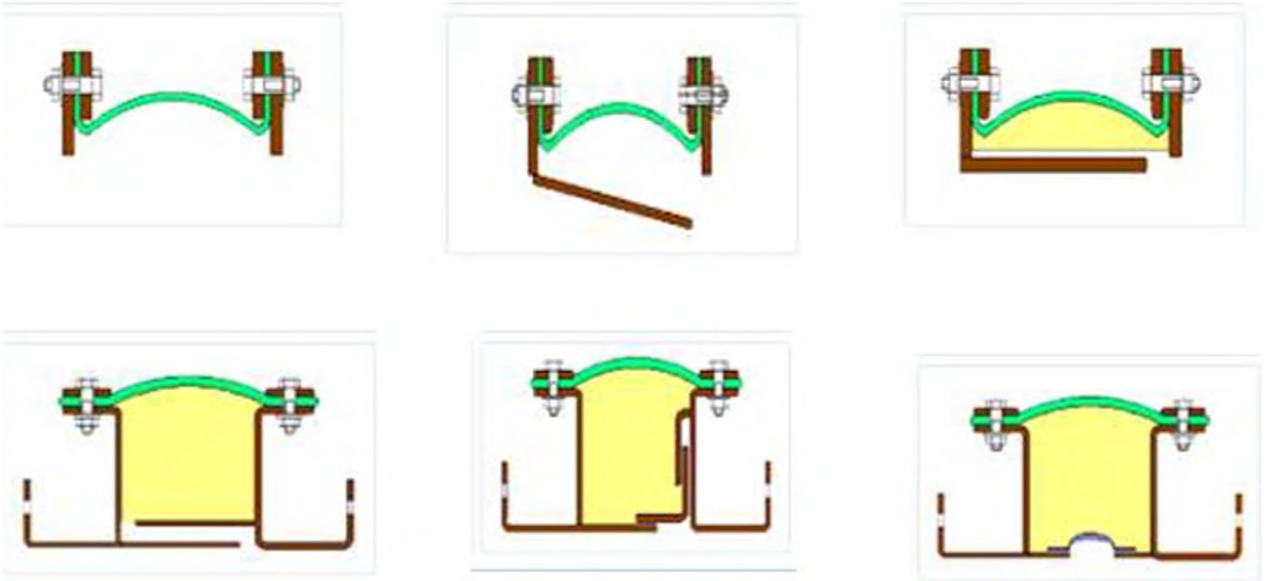

These flexible joints can be manufactured rectangular or circular without any limit to dimension and possibility to customize.

## Advantages

- Easy installment.
- Resistance to high temperatures.
- Manages all types of gases or vapors.
- Oppression of noise and vibration.
- Low replacement cost.
- Able to absorb all four types of basic movements.
- Able to absorb different movements simultaneously.
- Able to absorb big movements on minimum length.



## **Dispositivos Flexibles S.A. de C.V.**

Street 1 Norte, No. 3 Col. Atenatitlan,  
Jiutepec, Mor. México C.P. 62572  
Phone: 01(777) 319 45 06 / 320 5767

Fax: 320 2680

[Dispositivosflexibles@hotmail.com](mailto:Dispositivosflexibles@hotmail.com)

[www.dispoflex.com.mx](http://www.dispoflex.com.mx)